

Applications

Solar Monitoring for PV
Weather Services and Research
Climatology
Industrial Test Chambers

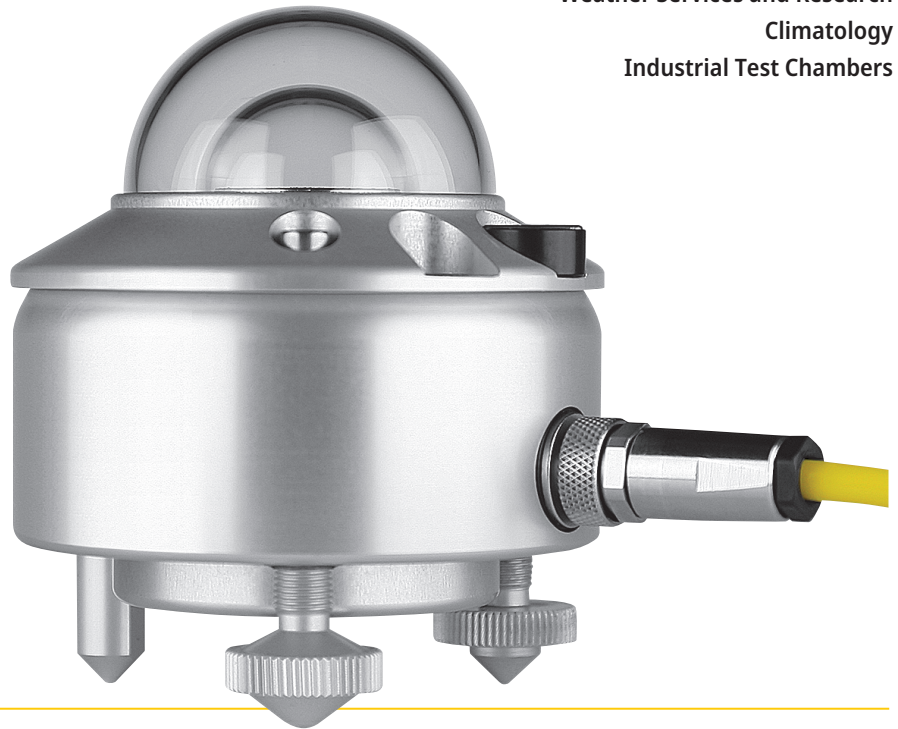

Pyranometer

For accurate measurement of solar irradiance

IEC61724 Class A

ISO 9060 Spectrally Flat Class A

The solar energy industry standard

Accurate and independent data for performance ratio calculations

Analog and digital outputs

5 year warranty

ISO 9060 & IEC 61724 Class A

Models CMP10, CMP11, SMP10 and SMP11 are the high quality pyranometers that are most commonly used in meteorological networks and solar energy applications around the world and all comply with Class A of ISO 9060 and IEC 61724.

Analog or digital outputs

CMP10 and CMP11 do not require any power. Incoming solar radiation generates a continuous millivolt output, which is converted in a data logger to irradiance in W/m^2 using the calibrated sensitivity. For easy integration into SCADA systems SMP10 and SMP11 have Modbus® RTU RS-485 serial communication, plus an amplified analog output. The sensitivity is stored inside for standardized outputs and they feature improved response time and better temperature compensation.

With or without drying cartridge

To prevent internal condensation, pyranometers are fitted with a desiccant to keep the internal humidity low and the accuracy high. CMP11 and SMP11 have an external drying cartridge with a desiccant that needs regular inspection and replacement every 3 to 6 months, depending on the local climate conditions. To save maintenance time and cost, CMP10 and SMP10 have internal desiccant that lasts up to 10 years.

5 Year Warranty

All pyranometers from Kipp & Zonen come with a 5 year warranty and we have service and calibration centers around the world.

Technical Specifications

	CMP10 CMP11	SMP10 SMP11
Classification to ISO 9060:2018	Spectrally Flat Class A	Spectrally Flat Class A
Sensitivity	7 to 14 $\mu\text{V}/\text{W}/\text{m}^2$	-
Impedance	10 to 100 Ω	-
Expected output range (0 to 1500 W/m^2)	0 to 20 mV	-
Maximum operational irradiance	4000 W/m^2	-
Analog output • V-version	-	0 to 1 V
Analog output range*	-	-200 to 2000 W/m^2
Analog output • A-version	-	4 to 20 mA
Analog output range*	-	0 to 1600 W/m^2
Serial output	-	RS-485 Modbus®
Serial output range	-	-400 to 4000 W/m^2
Response time (63 %)	< 1.7 s	< 0.7 s
Response time (95 %)	< 5 s	< 2 s
Spectral range (20 % points)	270 to 3000 nm	270 to 3000 nm
Spectral range (50 % points)	285 to 2800 nm	285 to 2800 nm
Zero offsets (unventilated)		
(a) thermal radiation (at 200 W/m^2)	< 7 W/m^2	< 7 W/m^2
(b) temperature change (5 K/h)	< 2 W/m^2	< 2 W/m^2
Non-stability (change/year)	< 0.5 %	< 0.5 %
Non-linearity (100 to 1000 W/m^2)	< 0.2 %	< 0.2 %
Directional response (up to 80 ° with 1000 W/m^2 beam)	< 10 W/m^2	< 10 W/m^2
Spectral selectivity (350 to 1500 nm)	< 3 %	< 3 %
Tilt response (0 ° to 90 ° at 1000 W/m^2)	< 0.2 %	< 0.2 %
Temperature response	< 1 % (-10 °C to +40 °C)	< 1 % (-20 °C to +50 °C) < 2 % (-40 °C to +70 °C)
Field of view	180 °	180 °
Accuracy of bubble level	< 0.1 °	< 0.1 °
Power consumption (at 12 VDC)	-	V-version: 55 mW A-version: 100 mW
Supply voltage	-	5 to 30 VDC
Software, Windows™	-	SmartExplorer Software, for configuration, test and data logging
Detector type	Thermopile	Thermopile
Operating and storage temperature range	-40 °C to +80 °C	-40 °C to +80 °C
Humidity range	0 to 100 %	0 to 100 %
MTBF (Mean Time Between Failures)	> 10 years	> 10 years **
Ingress Protection (IP) rating	67	67
Recommended applications	Meteorological networks, PV panel and thermal collector testing, materials testing	High performance for PV panel and thermal collector testing, solar energy research, solar prospecting, materials testing, advanced meteorology and climate networks

Note: The performance specifications quoted are worst-case and/or maximum values.

* adjustable with SmartExplorer Software | ** extrapolated after introduction in January 2012

Dimensions

